

REV	DATE	DESCRIPTION	DRAWN

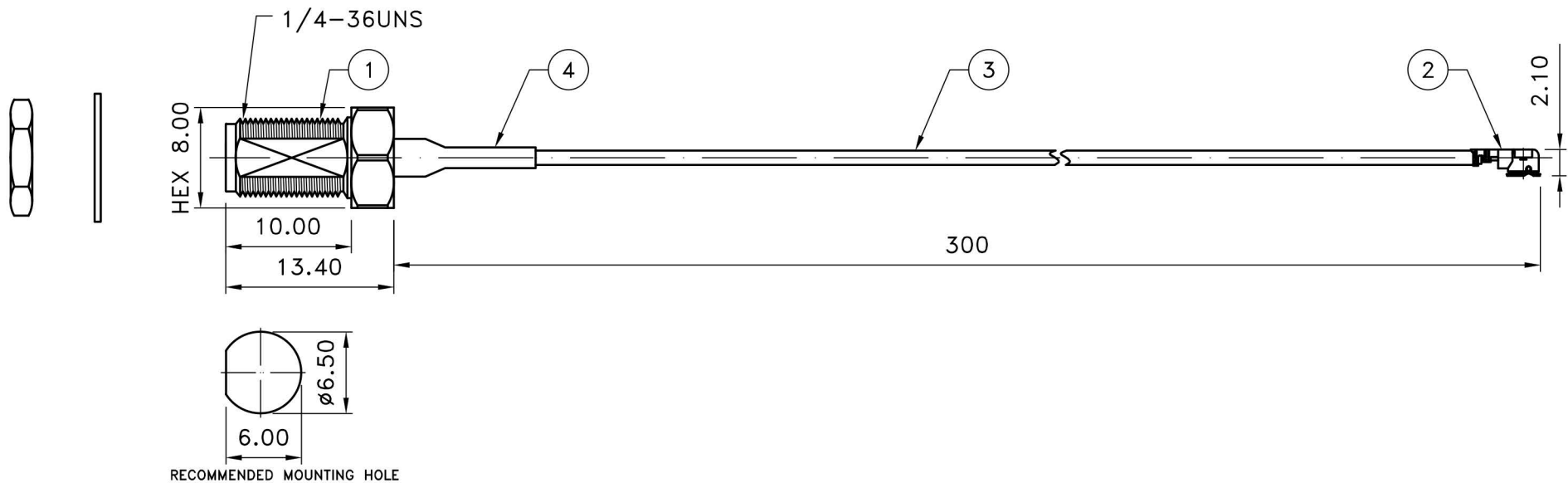

NOTE:  
 1.SMA FEMALE BULKHEAD SOLDER  
 BRASS PER JIS-C3604  
 FINISH PLATING THICKNESS IN MICRO-INCHES  
 COPPER PARTS AUTOMATIC CNC MANUFACTURING  
 2.1-PEX  
 CENTER PIN GOLD PLATING 0.1μ THICK  
 BODY GOLD PLATING 0.05μ THICK  
 LCP UL94V-0  
 PHOSPHOR BRONZE PER QQ-C-750  
 FINISH PLATING THICKNESS IN MICRO-INCHES  
 BRONZE PARTS AUTOMATIC CNC MANUFACTURING  
 3.φ1.13mm COAXIAL CABLE  
 ATTENUATION : 3.2dB/m@2.4GHz 3.7dB/m@3GHz 5.3dB/m@6GHz  
 CONDUCTOR : SA/∅0.24mm  
 INSULATION : FPE/∅0.718mm  
 SHIELD : TINNED COPPER WIRE/16\*4\*0.05mm  
 JACKET : MFA/∅1.137mm

Prohibit re-circulating

RoHS COMPLIANT

WIFI-Link™  
 台灣威海尼可

NO	DESCRIPTION	MATERIAL	FINISH	Q'ty
4	D0072 (SHRINK TUBE)	PE	BLACK	1
3	1.13 CABLE	ASSY	BLACK	1
2	IPEX-2601-6-1-DGG	BRASS	GOLD	1
1	SMA-1012-3-1-DGG	ZINC	GOLD	1

NOTE	DIMENSION
1.STRIP ALL BURRS. 2.ALL DIMENSIONS ARE AFTER PLATING. 3.DIAMETERS ON COMMON CENTERS. TO BE CONCENTRIC WITHIN 0.1 T.I.R 4.CHAMFER 1ST & LAST THREADS 45° 5.BREAK ALL CONNERS & EDGES CO.15 MAX.	UNLESS OTHERWISE NOTED TOLERANCES 0.X=±0.2 0.XX=±0.1 CABLE LENGTH: L ≥ 10000 = +50 1000 ≤ L < 10000 = +30 L < 1000 = +8

TITLE	
SMA1012-IPEX2601	
DRAWING NO.	
1012311326016-R300	
APPROVED	DRAWN DATE
	05/18/16
CHECKED	SCALE
	2:1
DRAWN	UNIT
ALICE	mm

\*All creative content and details belonging to HYT's confidential, and the owner, without consent, Do not posted, theft, copied and sent to a third party.\*